



## Audio Intimidation Wireless Microphone Frequencies

UK models only - including iTrans u216

When using two or more wireless microphones, or *radiomics*, it is important to select two frequencies which are more than 0.5 MHz apart to avoid co-channel interference and intermodulation between the systems

We have found that it is often possible to use Ch 11 - 863.100 MHz, Ch 13 - 863.500 MHz, Ch9 - 864.400 MHz and Ch 15 - 864.900 MHz when you need to use 4 deregulated and license free channels at the same time

All channels on these wireless microphones are in channel 70 - they are deregulated and license free in the UK & EU

iTrans u216 Channel	Frequency - MHz	DIP Switches
Ch 1	863.000	UDDD
Ch 2	863.400	DUDD
Ch 3	863.800	UUDD
Ch 4	864.200	DDUD
Ch 5	864.600	UDUD
Ch 6	863.200	DUUD
Ch 7	863.600	UUUD
Ch 8	864.000	DDDU
Ch 9	864.400	UDDU
Ch 10	864.800	DUDU
Ch 11	863.100	UUDU
Ch 12	863.300	DDUU
Ch 13	863.500	UDUU
Ch 14	863.700	DUUU
Ch 15	864.900	UUUU
Ch 16	865.000	DDDD

DIP switch settings on transmitters and receivers to set up frequencies

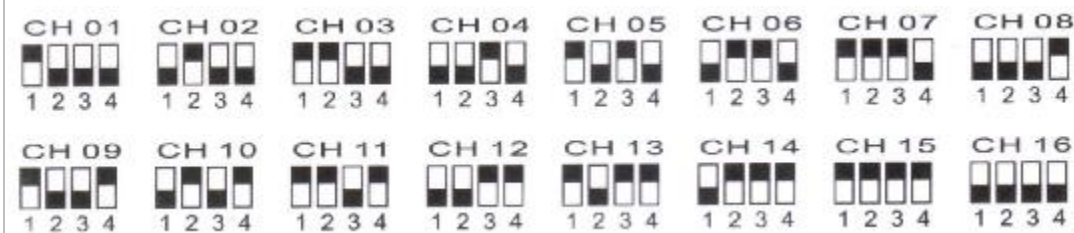

## Wireless Mic Aerial Lengths

The length of wireless receiving and transmitting aerials is critical and the following nominal values should be used when replacing broken or missing antenna on wireless mic equipment

Nominal Frequency	Band - Channel	Frequency Range	1/4 Wavelength Aerial Length
174.0 MHz	VHF	173.800 to 175.000 MHz	16" - 40.75cm
610.0 MHz	UHF - Ch 38	606.000 to 614.000 MHz	4" - 10.25cm
684 MHz	UHF - Ch 46 - 48	672.000 to 696.975 MHz	3.5" - 9cm
858.0 MHz	UHF - Ch 69	854.000 to 862.900 MHz	3.25" - 8.25cm
864.0 MHz	UHF - Ch 70	863.000 to 865.000 MHz	3.25" - 8.25cm

Use double the length for 1/2 wavelength aerials



### Phantom Power and Wireless Microphone Receivers

Many wireless microphone receivers are not protected from having phantom power connected to their balanced line audio outputs

By connecting a wireless mic receiver to a mixer or amplifier which has phantom power selected can often damage your receiver in moments

You can prevent this damage by having two 2.2mfd (2u2) 63v polarized capacitors in your XLR lead between the receiver and the mixer or amplifier. Taking care to ensure that the capacitors are the correct way round in series with the signals on each of pins 2 and pins 3 of your XLR lead

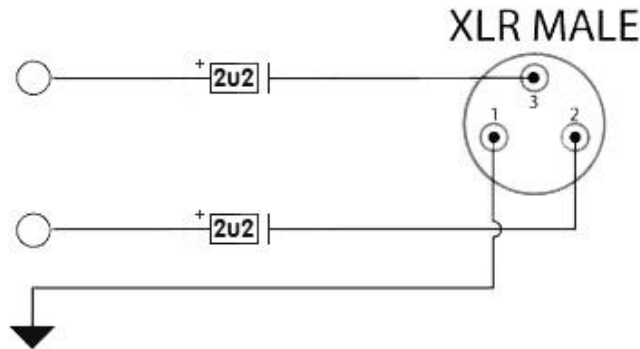

The positive of the capacitor should connect to the receiver and the negative of the capacitor should connect to the mixer or amplifier

### Attenuator Pads for Mics and Wireless Mic Receivers

Pads or attenuators are often needed to connect a wireless microphone receiver to over sensitive amplifier, PA sound system or mixer inputs. The mic pad will reduce the signal level so that the sound is less distorted and that the operator has more effective control over the volume

18.5db balanced mic pad attenuator

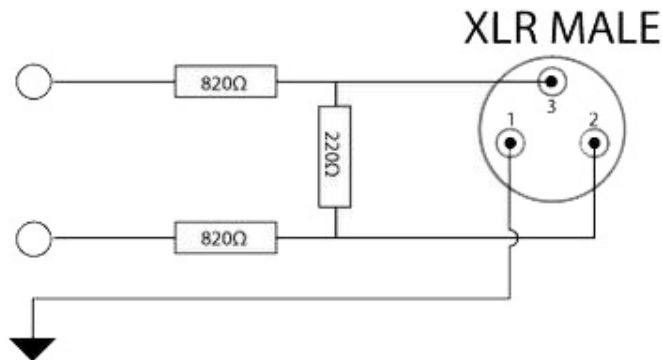

For unbalanced use replace 820 ohm resistor in the signal line with 1600 ohm (1K6) resistor, connect the 220 ohm resistor between signal and earth and do not use a resistor in earth / ground line

If you require less attenuation reduce the 820 ohm resistors to 390 ohms each for a 14db balanced mic pad

For ease, mount the three resistors in the male XLR connector that plugs into the amplifier or mixer

